

# CLARKE®

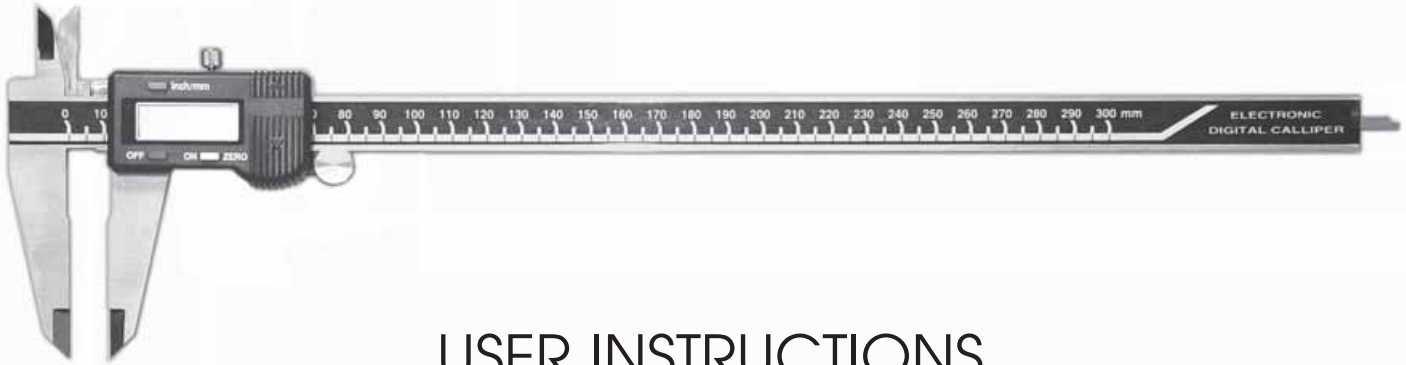

## USER INSTRUCTIONS



0207

# 300mm DIGITAL CALIPER

Model No: CM265 Part No: 4500365

Thank you for purchasing this CLARKE 300mm Digital Caliper.

Please read this instruction leaflet thoroughly and follow the instructions carefully, to ensure that the 300mm Digital Caliper will give you long and satisfactory service.

Please keep these instructions in a safe place for future reference.

## CLARKE GUARANTEE

This CLARKE product is guaranteed against faulty manufacture for a period of 12 months from the date of purchase.

Please keep your receipt as proof of purchase.

This guarantee is invalid if the product is found to have been abused or tampered with in any way, or not used for the purpose for which it was intended.

Faulty goods should be returned to their place of purchase, no product can be returned to us without prior permission.

This guarantee does not effect your statutory rights.

## TECHNICAL SPECIFICATION

### Product Specification:

Measuring Range: ..... 0mm - 306.97mm

Measuring Scale: ..... 0.01mm/0.0005"

Measuring Tolerances: ..... (0mm - 200mm: 0.03mm) (200mm - 300mm: 0.04mm)

Battery Type & Voltage: ..... Alkaline Cell (LR44) 1.55 Volt

## GENERAL PRECAUTIONS

- Keep the body of the caliper clean at all times, do not use alcohol or other corrosive chemicals as they could damage the internal electronics.
- Prevent accidental damage to the caliper by storing in its case when not in use.
- DO NOT immerse the caliper in liquid or allow liquid to enter the slide.



Waste electrical products should not be disposed of with household waste. Please dispose of at your local recycling facility.

Please Note that details and specifications herein, are correct of time of going to print.  
However CLARKE International reserve the right to change specifications at any time without prior notice.  
Copyright CLARKE International All rights Reserved 2006.

## GENERAL VIEW

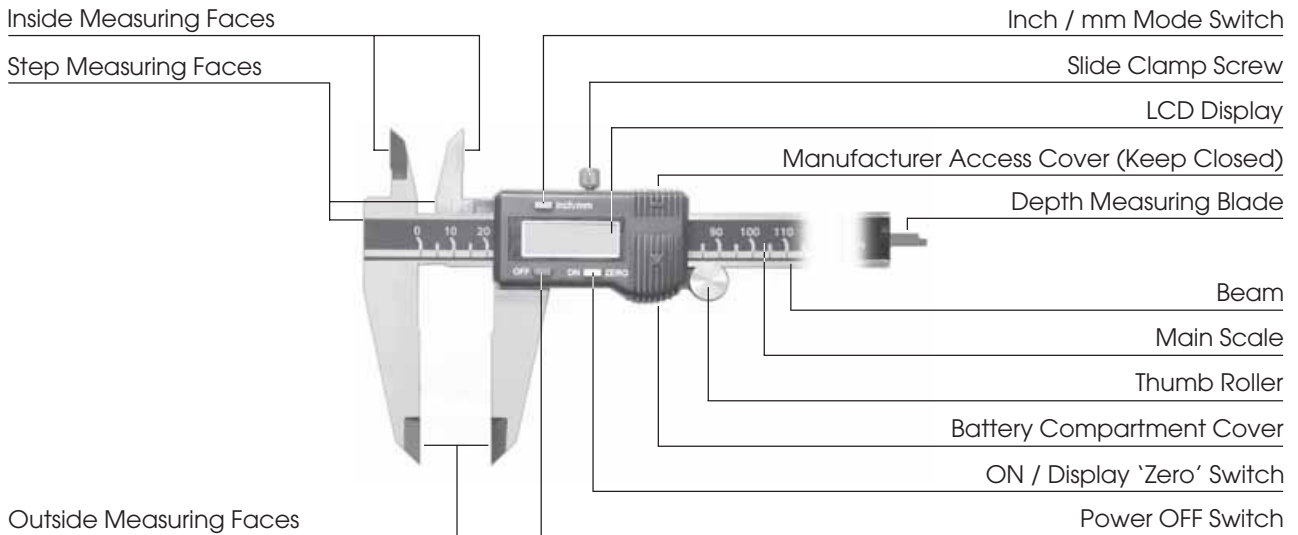

## SETUP AND OPERATION

- Loosen the slide clamp screw.
- Press the ON button to switch the calipers on, select the required measuring unit by pressing the inch/mm mode switch.
- Apply pressure to the thumb roller and close the caliper jaws, press the 'ZERO' button to zero the display.

### MEASURING APPLICATIONS:

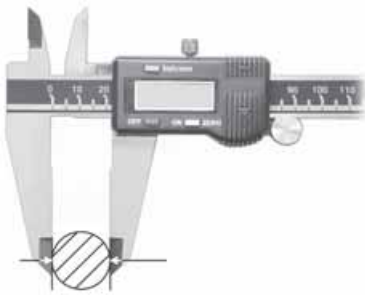

Measurement of external diameter.

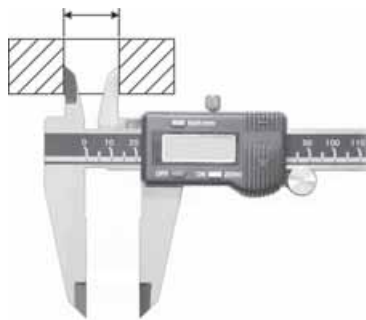

Measurement of internal diameter.

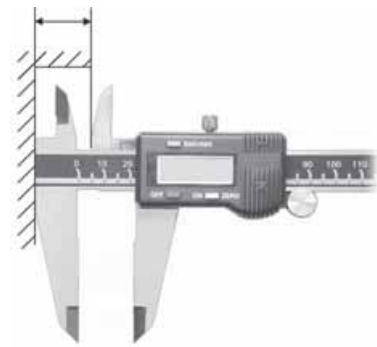

Measurement of steps.



Measurement of depth.

### BATTERY REPLACEMENT

When the display constantly flashes the battery requires replacement. Slide off the battery compartment cover and insert a new battery with the positive (+) side facing up.



### TROUBLE SHOOTING:

#### FAULT:

Display flashes constantly.  
 Display fails to change when slider is moved.  
 Display fails to function.  
 Measuring becomes less accurate.

#### CAUSE/SOLUTION:

Low battery - Replace battery.  
 Electronic fault - Remove battery & re-insert after 30 seconds.  
 Battery flat or in poor contact - Re-insert or replace battery.  
 Dirty sensor - Clean caliper thoroughly with compressed air.

For spare parts and servicing, please contact your nearest dealer, or CLARKE International on:

020 8988 7400 or email: [Parts@clarkeinternational.com](mailto:Parts@clarkeinternational.com)

[Service@clarkeinternational.com](mailto:Service@clarkeinternational.com)

CLARKE International, Hemnall Street, Epping, Essex, CM16 4LG