

Clarke® **METALWORKER**



BENCH GRINDER WITH LIGHT AND WHEEL DRESSER

MODEL NO: CBG6250L

PART NO: 6500524

OPERATION & MAINTENANCE INSTRUCTIONS



LS1111

INTRODUCTION

Thank you for purchasing this CLARKE Bench Grinder with light and wheel dresser.

Before attempting to use this product, please read this manual thoroughly and follow the instructions carefully. In doing so you will ensure the safety of yourself and that of others around you, and you can look forward to your purchase giving you long and satisfactory service.

GUARANTEE

This product is guaranteed against faulty manufacture for a period of 12 months from the date of purchase. Please keep your receipt which will be required as proof of purchase.

This guarantee is invalid if the product is found to have been abused or tampered with in any way, or not used for the purpose for which it was intended.

Faulty goods should be returned to their place of purchase, no product can be returned to us without prior permission.

This guarantee does not effect your statutory rights.

SPECIFICATIONS

Model Number	CBG6250L
Part Number	6500524
Rated Voltage	230V ~50Hz
Rated Input	250 W
No Load Speed	2850 RPM (+/- 5%)
Sound Pressure Level LpA	87 db
Sound Power Level LWA	97 db
Uncertainty Factor K	3
Weight	9.8 kg
Abrasive wheels supplied	Coarse (36 Grit), Fine (60 Grit)
Wheel dimensions	Diameter (150mm) Thickness (20 mm) Bore (12.7 mm)

POWER TOOL SAFETY WARNINGS

1) WORK AREA

1. **Keep the work area clean and well lit.** Cluttered and dark areas invite accidents.
2. **Do not operate power tools in explosive atmospheres, such as in the presence of flammable liquids, gases or dust.** Power tools create sparks which may ignite the dust or fumes.
3. **Keep children and bystanders away while operating a power tool.** Distractions can cause you to lose control.

2) ELECTRICAL SAFETY

1. **Power tool plugs must match the outlet. Never modify the plug in any way. Do not use adapter plugs with earthed (grounded) power tools.** Unmodified plugs and matching outlets will reduce the risk of electric shock.
2. **Do not expose power tools to rain or wet conditions.** Water entering a power tool will increase the risk of electric shock.
3. **Do not abuse the cable. Never use it for carrying, pulling or unplugging the power tool. Keep the cable away from heat, oil, sharp edges or moving parts.** Damaged or entangled cables increase the risk of electric shock.
4. **When operating a power tool outdoors, use an extension cable suitable for outdoor use.** Use of a cable suitable for outdoor use reduces the risk of electric shock
5. **If operating the power tool in a damp location is unavoidable, use a residual current device (RCD) protected supply.**

3) PERSONAL SAFETY

1. **Stay alert, watch what you are doing and use common sense when operating a power tool.** Do not use a power tool while you are tired or under the influence of drugs, alcohol or medication. A moment of inattention while operating power tools may result in personal injury.
2. **Use safety equipment. Always wear eye protection.** Safety equipment such as dust mask, non-skid safety shoes, hard hat, or hearing protection used for appropriate conditions will reduce personal injuries.
3. **Avoid accidental starting.** Ensure the switch is in the off position before plugging in. Carrying power tools with your finger on the switch or plugging in power tools that have the switch on invites accidents.
4. **Remove any wrench before turning the power tool on.** A wrench left attached to a rotating part may result in personal injury.
5. **Do not overreach.** Keep proper footing and balance at all times. This enables better control of the power tool in unexpected situations.
6. **Dress properly.** Do not wear loose clothing or jewellery. Keep your hair, clothing and gloves away from moving parts. Loose clothes, jewellery or long hair can be caught in moving parts.

4) POWER TOOL USE AND CARE

1. **Do not force the power tool.** Use the correct accessories for your application. The correct power tool will do the job better and safer at the rate which it was designed.
2. **Do not use the power tool if the switch does not turn it on and off.** Any power tool that cannot be controlled with the switch is dangerous and must be repaired.
3. **Disconnect the plug from the power source before changing accessories, or storing power tools.** Such preventive safety measures reduce the risk of starting the power tool accidentally.
4. **Store idle tools out of the reach of children and do not allow persons unfamiliar with the power tool or these instructions to operate it.** Power tools are dangerous in the hands of untrained users.
5. **Maintain power tools.** Check for misalignment or binding of moving parts, breakage of parts and any other condition that may affect the power tool's operation. If damaged, have the power tool repaired before use. Many accidents are caused by poorly maintained power tools.
6. **Use the power tool and accessories in accordance with these instructions and in the manner intended, taking into account the working conditions and the work to be performed.** Use of the power tool for operations different from intended could result in a hazardous situation.
7. The performance of this tool may vary, depending upon variations in line voltage. Extension cable usage may also affect performance.

5) SERVICE

1. **Have your power tool serviced by qualified service personnel using only identical replacement parts.** This will ensure that the safety of the power tool is maintained.

BENCH GRINDER SAFETY WARNINGS

1. Hold the hand tool or blade being sharpened firmly to prevent loss of control.
2. NEVER install a abrasive flap wheel or sanding disc on this grinder.
3. Always replace a cracked grinding wheel immediately.
4. Never use damaged or incorrect grindstones. The stone and retaining bolt were specially designed for your grinder, for optimum performance and safety of operation. Inspect the condition of the grinding stone before use and do not use if any damage is noticed.
5. Do not use aluminium oxide wheels when grinding non-ferrous metals such as aluminium or brass. Use silicon carbide wheels (not included) for grinding non-ferrous metals.
6. Always use the tool rests to steady the workpiece. If the tool attachments are not used, the torque of the spinning grinding/polishing wheel may pull the workpiece from your hands.
7. Never leave the grinder unattended when it is connected to an electrical power supply. Switch off the machine and unplug it before leaving.

8. ALWAYS check for damaged parts. Before further use of the tool, a guard or other part that is damaged should be carefully checked to determine if it would operate properly and perform its intended function. Check for misalignment or binding of moving parts, breakage of parts and any other condition that may affect the tool's operation. A part that is damaged should be properly repaired or replaced at an authorised service Centre. Following this rule will reduce the risk of electric shock, fire or serious injury.
9. Gloves, manufactured to the current European safety standards should be worn when operating grinding equipment.
10. Eye protection manufactured to the current European safety standards should be worn when operating grinding equipment.

Note: Bench grinders used in industrial environments may be subject to the requirements of The Provision and Use of Work Equipment regulations 1992 (particularly regarding the training requirement of The Abrasive Wheels Regulations 1970), or other legislation. If in doubt seek advice.

Please keep these instructions in a safe place for future reference.

SAFETY SYMBOLS

	Read Instruction Manual Before Use
	This Machine Is Not Suitable For Hand Held Use
	Not Permitted For Wet Grinding
	Wear Eye Protection
	Wear Ear Defenders
	Wear Protective Gloves

ELECTRICAL CONNECTIONS



WARNING! Read these electrical safety instructions thoroughly before connecting the product to the mains supply.

Before switching the product on, make sure that the voltage of your electricity supply is the same as that indicated on the rating plate. This product is designed to operate on 230VAC 50Hz. Connecting it to any other power source may cause damage.

This product may be fitted with a non-rewireable plug. If it is necessary to change the fuse in the plug, the fuse cover must be refitted. If the fuse cover becomes lost or damaged, the plug must not be used until a suitable replacement is obtained.

If the plug has to be changed because it is not suitable for your socket, or due to damage, it should be cut off and a replacement fitted, following the wiring instructions shown below. The old plug must be disposed of safely, as insertion into a mains socket could cause an electrical hazard.



**WARNING! The wires in the power cable of this product are coloured in accordance with the following code:
Blue = Neutral Brown = Live Yellow and Green = Earth**

If the colours of the wires in the power cable of this product do not correspond with the markings on the terminals of your plug, proceed as follows.

- The wire which is coloured **Blue** must be connected to the terminal which is marked **N** or coloured **Black**.
- The wire which is coloured **Brown** must be connected to the terminal which is marked **L** or coloured **Red**.
- The wire which is coloured **Yellow and Green** must be connected to the terminal which is marked **E** or \perp or coloured **Green**.

Plug must be BS1363/A approved.

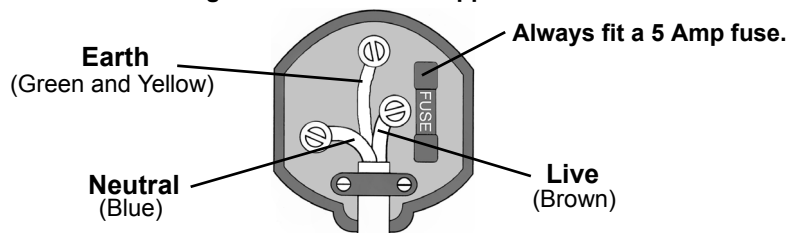

Ensure that the outer sheath of the cable is firmly held by the clamp

We strongly recommend that this machine is connected to the mains supply via a Residual Current Device (RCD)

If in any doubt, consult a qualified electrician. DO NOT attempt any repairs yourself.

CARTON CONTENTS

The following items should be supplied in the carton. If any parts are missing or damaged, please contact the Clarke dealer where you purchased the bench grinder.

1 x Bench Grinder Assembly (2 grinding wheels attached)
2 x Eye Shields (1 with Built-in Magnifying Lens)
2 x Eye Shield Arms with bolts and washers
2 x Eye Shield Brackets
2 x Hand Knobs with washers
2 x Spark Deflectors with bolts and washers
2 x Tool Rests with screws and washers (1 flat and 1 with a channel for sharpening drill bits)
1 x Wheel Dresser

PART IDENTIFICATION

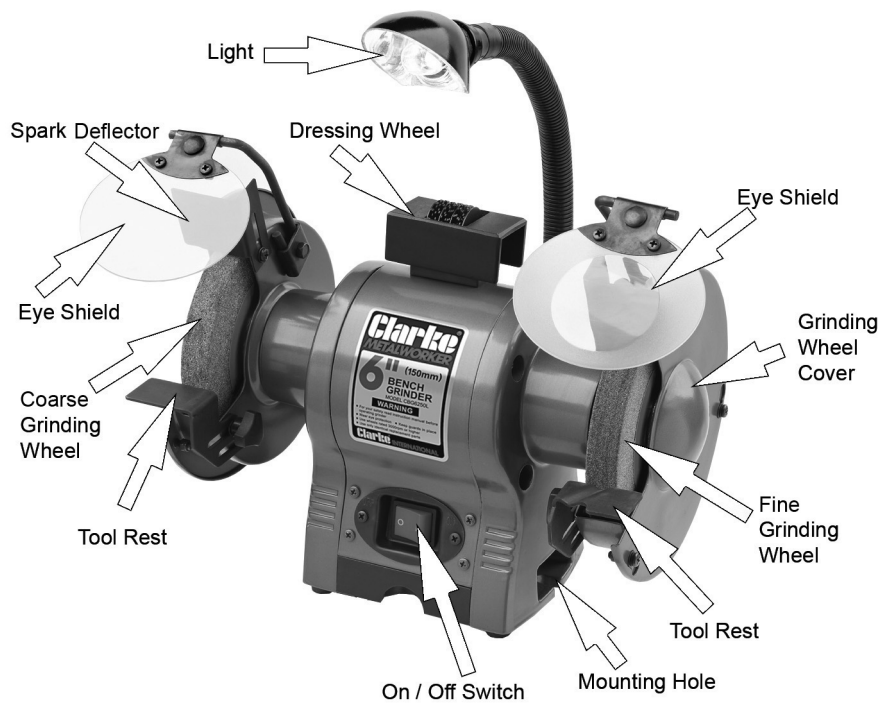

BEFORE USE

MOUNTING THE GRINDER ON A WORKBENCH

NOTE: We highly recommend that you bolt this bench grinder securely to a workbench to gain maximum stability for your machine.

1. Using the base of the bench grinder as a template, mark the bench through the holes in the casting.
2. Bolt the bench grinder to the bench with bolts, washers and nuts (not supplied).
3. To reduce vibration, mount the bench grinder on a vibration absorbing mat.

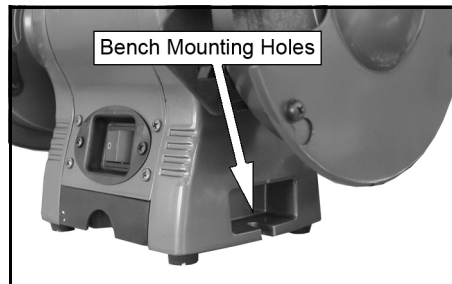

INSTALLING THE TOOL RESTS

1. Fix the tool rests to the bench grinder with the screw and hand knob as shown.
 - The tool rests are adjustable and should be positioned 1.5 mm from the grinding wheels.
 - Ensure that the tool rest is firmly fixed and horizontal.
 - One of the tool rest has a angled groove to allow you to sharpen the ends of drill bits.

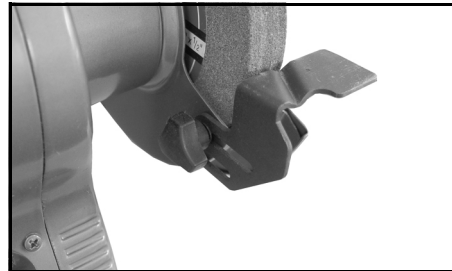

INSTALLING THE SPARK DEFLECTORS

Fit both the spark deflectors to the wheel guards using the screws provided.

- Adjust the spark deflector frequently to compensate for wear of the wheel, keep the distance between the spark deflector and wheel as small as possible and never more than 2mm.

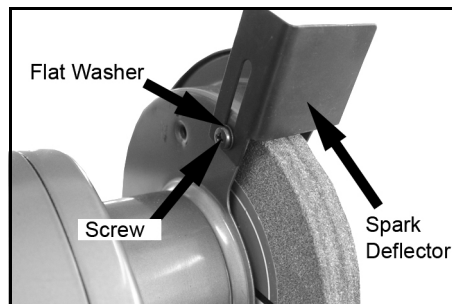

INSTALLING THE EYE SHIELDS

1. Attach the left eye shield arm to the bench grinder using the bracket, flat washer and bolt supplied.
2. Fit the lens to the lens holder as shown.
3. Repeat for right side eye shield.

NOTE: Adjust the eye shields to an appropriate distance from the tool rests avoiding interference during operation.

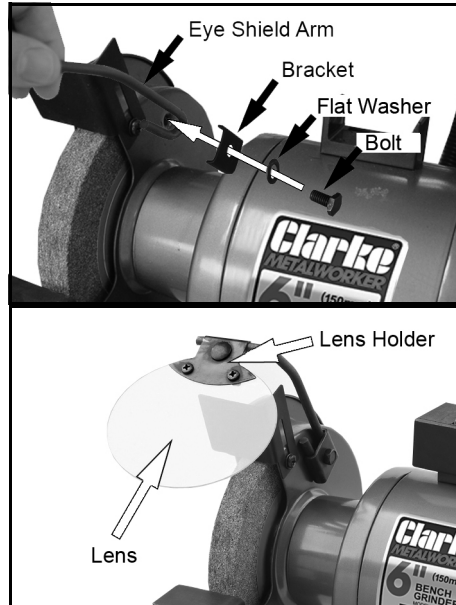

SHARPENING TIPS

SCISSORS

If possible, take the scissors apart to make the sharpening operation easier and safer. Remove material only from the outside surface and work from the handle end of the blade toward the tip.

KNIVES

Remove metal equally from both faces, working from the handle end of the blade toward the tip.

OPERATION



CAUTION: KEEP ALL BYSTANDERS A SAFE DISTANCE AWAY FROM THE TOOL AND NOT IN DIRECT LINE, FRONT OR BACK OF THE GRINDER.

CAUTION: ALWAYS WEAR SAFETY GLASSES

NOTE: Check that there is a 1.5 mm clearance between the tool rests and the surface of the grinding wheel. Adjust as necessary.

NOTE: Check the gap between the spark deflectors and the surface of the grinding wheel. These should also be a maximum of 2 mm. Adjust as necessary.

NOTE: Check that the eyeshields have been secured in the correct position and that the grinding wheel lock nuts are tight.

1. Stand to the side of the bench grinder and switch it on using the on/off switch.
 - Let the grinding wheel reach full speed before grinding.
 - The wheel rotates in the same direction as the arrow stamped in the side of the wheel guard.
2. Hold the work piece firmly against the tool rest. Hold very small pieces with pliers or other suitable clamps.
3. Feed the work piece smoothly and evenly against the grinding wheel.
4. Always keep the work piece moving across the face of the wheel. Grinding against the same part of the wheel will cause uneven wear of the wheel face.
 - Grind only on the face of the grinding wheel and never the side of it.

NOTE: Prolonged grinding will cause most tools to become hot. Use care when handling hot tools.

5. Switch the bench grinder off using the on/off switch when you have finished.

USING THE BUILT IN LIGHT

The built in light will come on automatically whenever the bench grinder is switched on.

The arm can bend to set the light in a suitable position.

MAINTENANCE



WARNING: DISCONNECT THE GRINDER FROM THE MAINS SUPPLY BEFORE FITTING REPLACEMENT WHEELS, CLEANING OR ADJUSTMENT.

Keep the machine clean by wiping off dust with a clean cloth, and occasionally blowing the grinder through with compressed air. Always wear protective goggles when blowing through with compressed air.

The grinding wheel may need truing or dressing occasionally. Only dress the wheel with a proper dressing tool, whilst wearing safety goggles or glasses. If in doubt seek expert advice.

DRESSING THE WHEEL

When the wheels start to become clogged with debris, use the dresser tool supplied to clean (dress) them.

1. Start the bench grinder running
2. Place the dresser tool on the tool rest with the dresser wheels facing the abrasive wheel.
3. Slide the dresser tool forward until contact is made with the abrasive wheel and maintain a light pressure to clean the debris from the abrasive wheel.
4. After dressing, adjust the tool rests and spark deflectors as necessary.

CHANGING THE LIGHT BULB

Remove the bulb by twisting it anticlockwise.

Replace with an identical bulb (12V, 10W, ES10 fitting) available from the Clarke Parts Department.

REPLACING THE GRINDING WHEELS



WARNING: DO NOT USE DAMAGED GRINDING WHEELS.

WARNING: SWITCH THE GRINDER OFF AND DISCONNECT THE POWER SUPPLY BEFORE CHANGING THE GRINDING WHEELS

1. Loosen the screws shown and rotate and remove the cover.
2. Hold the other wheel by hand, and remove the nut and outer flange.

NOTE: The left hand grinding wheel locking nut has a left handed thread.

3. Slide off the old wheel and replace with a new one.



- Use only wheels recommended by the manufacturer which have a marked speed equal to or greater than the speed marked on the nameplate of the tool
- The disc should have maximum dimensions of 150 mm diameter, 20 mm thick with a bore size of 12.7 mm.
- Inspect the wheel for cracks, chips or any other visible damage, damaged abrasive products must be destroyed and discarded

4. Replace the outer flange.
 - Make sure both wheel flanges are placed with the concave sides towards the wheel.
5. Replace the nut securely.
 - Do not overtighten as this may damage the grinding wheel.
6. Re-assemble the guards fully prior to carrying out testing.

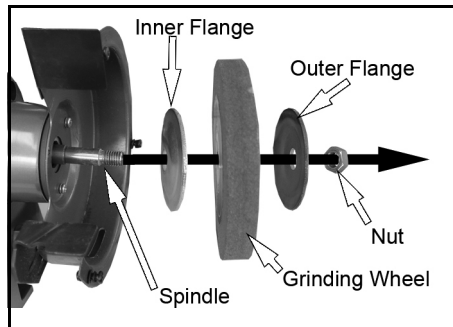

- Each time after mounting, the wheel should be test run for a reasonable time (approximately 1 minute).

PARTS DIAGRAM

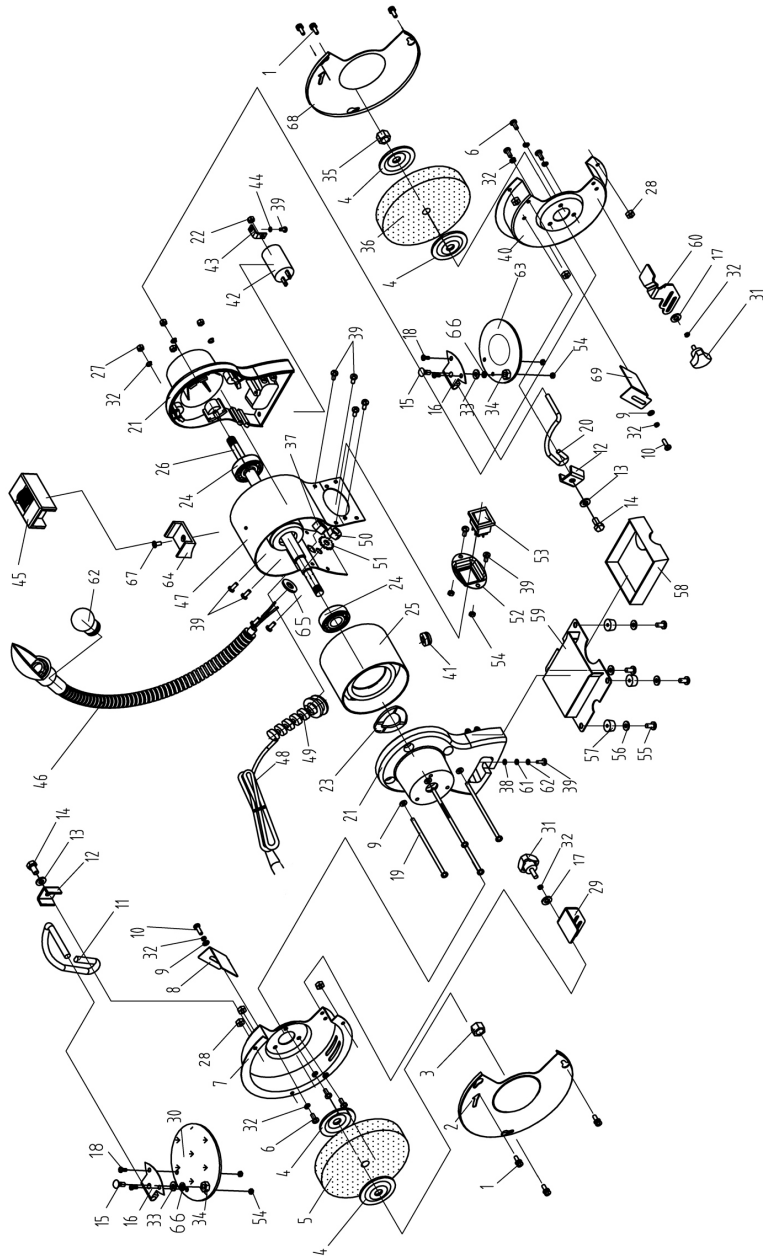

PARTS LIST

1	Phillips Screw Assembly	WACBG6250L01	37	Locked Nut	WACBG6250L37
2	Left Guard Cover	WACBG6250L02	38	Toothed Locking Washer	WACBG6250L38
3	I type Hex Nut	WACBG6250L03	39	Phillips Screw	WACBG6250L39
4	Wheel Flange	WACBG6250L04	40	Right Guard	WACBG6250L40
5	Wheel(36#)	WACBG6250L05	41	Cable Grommet	WACBG6250L41
6	Phillips Screw	WACBG6250L06	42	Capacitor	WACBG6250L42
7	Left Guard	WACBG6250L07	43	Capacitor holder	WACBG6250L43
8	Left Spark Deflector	WACBG6250L08	44	Washer	WACBG6250L44
9	Flat Washer	WACBG6250L09	45	Dressing Wheel	WACBG6250L45
10	Phillips Screw	WACBG6250L10	46	Lamp Assembly	WACBG6250L46
11	L/H Eyeshield mount rod	WACBG6250L11	47	Motor housing	WACBG6250L47
12	Bracket	WACBG6250L12	48	Cord & Plug	WACBG6250L48
13	Flat Washer	WACBG6250L13	49	Strain relief	WACBG6250L49
14	Hex Bolt	WACBG6250L14	50	Nut	WACBG6250L50
15	Dome Screw	WACBG6250L15	51	Toothed Locking Washer	WACBG6250L51
16	Eyeshield Plate	WACBG6250L16	52	Switch Plate	WACBG6250L52
17	Big Flat Washer	WACBG6250L17	53	Switch	WACBG6250L53
18	Phillips Screw	WACBG6250L18	54	Hex nut	WACBG6250L54
19	Phillips Screw	WACBG6250L19	55	Phillips Screw	WACBG6250L55
20	R/H Eyeshield mount rod	WACBG6250L20	56	Flat washer	WACBG6250L56
21	End cap	WACBG6250L21	57	Rubber foot	WACBG6250L57
22	I type Hex Nut	WACBG6250L22	58	Tool tray	WACBG6250L58
23	Wavy washer	WACBG6250L23	59	Base Plate	WACBG6250L59
24	Ball bearing	WACBG6250L24	60	R/H work rest	WACBG6250L60
25	Stator	WACBG6250L25	61	Flat washer	WACBG6250L61
26	Rotor	WACBG6250L26	62	Bulb	WACBG6250L62
27	Nut	WACBG6250L27	63	Magnified eye shield	WACBG6250L63
28	Lock Nut	WACBG6250L28	64	Dressing tool base	WACBG6250L64
29	L/H work rest	WACBG6250L29	65	Flat washer	WACBG6250L65
30	Eyeshield	WACBG6250L30	66	Standard Washer	WACBG6250L66
31	Work Rest Lock knob	WACBG6250L31	67	Phillips Screw	WACBG6250L67
32	Standard Washer	WACBG6250L32	68	Right Guard Cover	WACBG6250L68
33	Flat Washer	WACBG6250L33	69	Right Spark Deflector	WACBG6250L69
34	I type Hex Nut	WACBG6250L34			
35	Nut	WACBG6250L35			
36	Wheel(60#)	WACBG6250L36			

DECLARATION OF CONFORMITY



Clarke[®]
INTERNATIONAL

Hemnall Street, Epping, Essex CM16 4LG

DECLARATION OF CONFORMITY

This is an important document and should be retained.

We hereby declare that this product(s) complies with the following directive(s):

2004/108/EC Electromagnetic Compatibility Directive.

2006/42/EC Machinery Directive.

2006/95/EC Low Voltage Equipment Directive.

2002/95/EC Restriction of Hazardous substances.

The following standards have been applied to the product(s):

N.A

The technical documentation required to demonstrate that the product(s) meet(s) the requirement(s) of the aforementioned directive(s) has been compiled and is available for inspection by the relevant enforcement authorities.

The CE mark was first applied in: 2007

Product Description: 6" Bench Grinder 250W, 6" Bench Grinder 250W with Light
6" Bench Grinder 250W with Light and Wire Wheel.
Model number(s): CBG6250, CBG6250L, CBG6250LW
Serial / batch Number: N/A
Date of Issue: 08/03/2011

Signed:

J.A. Clarke
Director

A SELECTION FROM THE VAST RANGE OF

Clarke®

QUALITY PRODUCTS



AIR COMPRESSORS
From DIY to industrial, Plus air tools, spray guns and accessories.

GENERATORS
Prime duty or emergency standby for business, home and leisure.

POWER WASHERS
Hot and cold, electric and engine driven - we have what you need

WELDERS
Mig, Arc, Tig and Spot. From DIY to auto/industrial.

METALWORKING
Drills, grinders and saws for DIY and professional use.

WOODWORKING
Saws, sanders, lathes, mortisers and dust extraction.

HYDRAULICS
Cranes, body repair kits, transmission jacks for all types of workshop use.

WATER PUMPS
Submersible, electric and engine driven for DIY, agriculture and industry.

POWER TOOLS
Angle grinders, cordless drill sets, saws and sanders.

STARTERS/CHARGERS
All sizes for car and commercial use.



PARTS & SERVICE: 020 8988 7400

E-mail: Parts@clarkeinternational.com or Service@clarkeinternational.com

SALES: UK 01992 565333 or Export 00 44 (0)1992 565335

Clarke INTERNATIONAL Hemnall Street, Epping, Essex CM16 4LG
www.clarkeinternational.com