

ClarkeTM
air



HEAVY DUTY BELT SANDER

MODEL NO: CAT 70

PART No: 3110750

OPERATION & MAINTENANCE
INSTRUCTIONS



0906

SPECIFICATIONS

Model: CAT 70
 Part No: 3110750
 Belt Speed: 1500 M/Min
 Maximum Air Consumption: 17 CFM
 Standard Belt Size 20mm x 520mm
 Recommended Air Pressure 90 PSI (6.2bar)
 Air Inlet Size 1/4" BSP
 Minimum Hose Size 5/16" (8mm)
 Overall Length 345mm
 Weight 1.2 kg
 Noise Level 90 dB(A)

Please note that the details and specifications contained herein are correct at the time of going to print. However CLARKE International reserve the right to change specifications at any time without prior notice. Always consult the machines data plate

HAND-ARM VIBRATION

Employers are advised to refer to the HSE publication "Guide for Employers".

All hand held power tools vibrate to some extent, and this vibration is transmitted to the operator via the handle, or hand used to steady the tool. Vibration from about 2 to 1500 herz is potentially damaging and is most hazardous in the range from about 5 to 20 herz.

Operators who are regularly exposed to vibration may suffer from Hand Arm Vibration Syndrome (HAVS), which includes 'dead hand', 'dead finger', and 'white finger'. These are painful conditions and are widespread in industries where vibrating tools are used.

The health risk depends upon the vibration level and the length of time of exposure to it.....in effect, a daily vibration dose.

Tools are tested using specialised equipment, to approximate the vibration level generated under normal, acceptable operating conditions for the tool in question. For example, a grinder used at 45° on mild steel plate, or a sander on softwood in a horizontal plane etc.

These tests produce a value 'a', expressed in metres per second per second, which represents the average vibration level of all tests taken, in three axes where necessary, and a second figure 'K', which represents the uncertainty factor, i.e. a value in excess of 'a', to which the tool could vibrate under normal conditions. These values appear in the specification panel below.

For an explanation of Hand-Arm Vibration, please see page 7

MODEL No:	CAT70
DESCRIPTION:	20mm BELT SANDER
Declared vibration emission value in accordance with EN12096	
Measured vibration emission value - α :	<2.5m/s ²
Uncertainty value - K:	m/s ²
Highest measured reading in a single plane	0.39m/s ²
Values determined according to EN28622-1	



Please read these instructions carefully before operating the tool

Thank you for purchasing this **CLARKE** Air Heavy Duty Belt Sander
Before using the device, please read this manual thoroughly and carefully follow all instructions given. This is for your own safety and that of others around you, and is also to help you achieve long and trouble free service from your new tool.

CLARKE GUARANTEE

This CLARKE product is guaranteed against faulty manufacture for a period of 12 months from the date of purchase. Please keep your receipt as proof of purchase.

This guarantee is invalid if the product is found to have been abused or tampered with in any way, or not used for the purpose for which it was intended.

Faulty goods should be returned to their place of purchase, no product can be returned to us without prior permission.

This guarantee does not affect your statutory rights.

PARTS & SERVICE TEL: 020 8988 7400

or e-mail as follows:

PARTS: Parts@clarkeinternational.com

SERVICE: Service@clarkeinternational.com

ACCESSORIES

A wide range of Airline accessories is available, including Filter/Regulators, Lubricators, High Pressure Hoses from 5 to 100 Metres, etc. Contact your CLARKE dealer for further information, or CLARKE International Sales Department on 01992 565300

SAFETY PRECAUTIONS

IMPORTANT

Failure to follow these precautions could result in personal injury, and/or damage to property.

- ❑ When operating this tool, ALWAYS wear:
 - a. approved impact resistant SAFETY GOGGLES. (Eye glasses are NOT safety glasses)
 - b. a DUST MASK
 - c. EAR DEFENDERS
 - d. a good pair of INDUSTRIAL GLOVES
- ❑ **ALWAYS** disconnect the tool when not in use, and before carrying out any maintenance
- ❑ **ALWAYS** keep a safe distance between yourself and other people when using the tool.
- ❑ **ALWAYS** maintain the tool with care. Keep it clean for best and safest performance.
- ❑ **NEVER** wear ill fitting clothing, remove watches and rings.
- ❑ Quick change couplings should not be located at the tool. They add weight and could fail due to vibration.
- ❑ **DO NOT** over-reach. Keep your proper footing and balance at all times.
- ❑ **DO NOT** force or misuse the tool. It will do a better and safer job at the rate for which it was designed.
- ❑ **DO NOT** abuse hoses or connectors. NEVER carry a tool by the hose, or yank it to disconnect from the air supply. Keep hoses away from heat, oil and sharp edges. Check hoses for leaks or worn condition before use, and ensure that all connections are secure.
- ❑ **DO NOT** exceed 90 PSI at the tool.
- ❑ **DO NOT** modify the tool in any way.
- ❑ **DO NOT** remove any labels. Damaged labels should be replaced.
- ❑ This tool vibrates with use. Vibration may be harmful to your hands or arms. Stop using the tool if discomfort, a tingling feeling or pain occurs. Seek medical advice before resuming use.
- ❑ **ALWAYS** use screens to protect people in the vicinity from flying debris.
- ❑ **NEVER** point the tool at anyone.

AIR SUPPLY

Tools of this type, operate on a wide range of air pressures. It is recommended that air pressure to this tool does not exceed 90 PSI (6.1bar), at the tool when running. Higher pressure and unclean air, will shorten the tools' life because of faster wear, and could be a safety hazard.

Water in the air line will cause damage to the tool, ensure it is properly maintained at all times.

The recommended procedure to connect this tool to an air supply, is shown on Page 7.

The air inlet used for connecting air supply, has a standard 1/4" BSP thread.

Line pressure, or hose inside diameter, should be increased to compensate for unusually long air hoses (over 10m). Minimum hose diameter should be 6mm (1/4") ID., and fittings should have the same inside dimensions.

ASSEMBLY

Connect a suitable hose to the Sander using a 1/4" hose adapter, (A whip hose with Quick Fit coupling is available from your CLARKE dealer), then connect the other end to the airline.

NOTE: ensure the airline is turned off.

Your Sander is now ready for use.

⚠ WARNING ⚠

Compressed air can be dangerous. Ensure that you are thoroughly familiar with all precautions relating to the use of compressors and compressed air supply.



OPERATING INSTRUCTIONS

Before starting work drain any water from the air tank and blow condensation from the air line. Drain compressor more frequently in hot humid weather.

1. Ensure that tool is disconnected from air supply.
2. To replace sanding belt push the idle pulley assembly (Item 2) towards the handle until it clicks into secured position. Replace belt and press tension bar (Item 14), see Fig.1 below.
3. To track belt, adjust as required with screw 2A Fig. 1.
4. To adjust handle position, slacken screw (Item 11), rotate handle to the required position (**Only as far as A or B**), then secure by re-tightening screw (Item 11).
5. Connect to airline, turn air on.
6. Ensure fingers are clear of sanding belt, depress throttle lever to start motor, allow motor to reach max speed before offering belt to workpiece.
7. Do not use finger pad (Item 4) to exert pressure on belt; this item is only for guiding the tool.
8. When finished sanding, release throttle lever and allow motor to stop before carefully putting tool down.

Fig.1

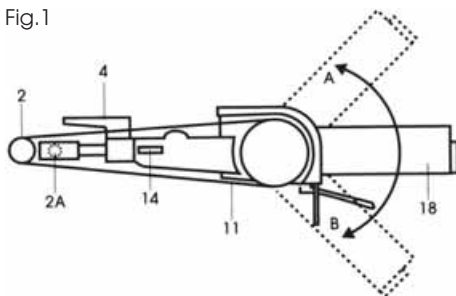

Clarke INTERNATIONAL

MAINTENANCE

Daily before use.

1. Drain water from air tank, air line and compressor.
2. Check and clean, if necessary, the air inlet gauze filter .
3. Pour a few drops of CLARKE Air Line Oil (approx 3cc), into the air inlet. This should be carried out regardless of whether or not an air line lubricator is used. If an Air line lubricator is NOT used, this procedure should be repeated after every two to three hours of use.

If the sander is to be stored, or is idle for longer than 24 hours, run a few drops of Clarke Air Line Oil into the air inlet, and run the tool for 5 seconds in order to lubricate the internal parts.

For lubricating the air motor when in operation, an air line lubricator should be used, with Clarke Air Line Oil, adjusted to 2 drops per minute.

Clarke Air Line Oil is available from your CLARKE dealer, part no. 3050825.

Be aware that factors other than the tool may effect its operation and efficiency, such as reduced compressor output, excessive drain on the airline, moisture or restrictions in the line, or the use of connectors of improper size or poor condition which will reduce air supply.

Grit or gum deposits in the tool may also reduce efficiency. This condition can be corrected by cleaning the air strainer and flushing out the tool with gum solvent oil, or failing this, the tool should be dis-assembled, thoroughly cleaned, dried and re-assembled.

If the tool runs erratically or becomes inefficient, and the air supply is sound, dismantle the air motor and replace worn or damaged parts, or take the tool to your CLARKE dealer.

IMPORTANT:

The use of parts other than CLARKE replacement parts may result in safety hazards, decreased tool performance and may invalidate your warranty.

PARTS DIAGRAM

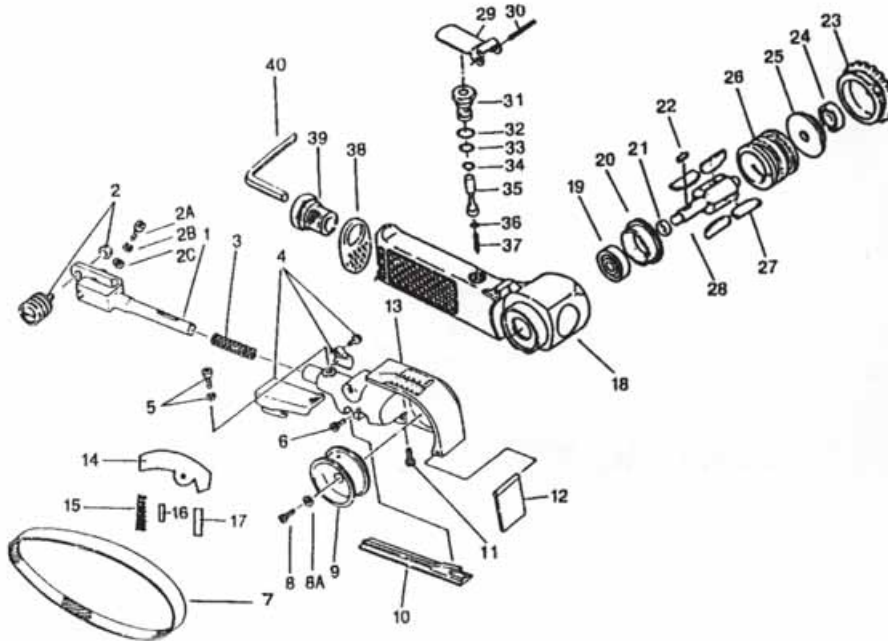

PARTS LIST

Index No.	Part No.	Description	Qty	Index No.	Part No.	Description	Qty
1	KL0707001	Idle Pulley Sub Assy	1	20	KL0707020	End Plate B	1
2	KL0707002	Idle Pulley Assy	1	21	KL0707021	Spacer 10x13x3	1
2A	KL0707002A	Socket Head Bolt 5x28	1set	22	KL0707022	Sunk Key 2x2.5x10	1
2B	KL0707002B	Washer	1	23	KL0707023	Cap	1
2C	KL0707002C	'C' Clip	1	24	KL0707024	Ball Bearing 626ZZ	1
3	KL0707003	Spring	1	25	KL0707025	End Plate A	1set
4	KL0707004	Finger Pad Assy	3	26	KL0707026	Cylinder	1
5	KL0707005	Key Bolt Assy	2	27	KL0707027	Blade Assy	1set
6	KL0707006	Socket Head Bolt 5x12	1	28	KL0707028	Rotor	1
7	KL0707007	Sanding Belt	2	29	KL0707029	Throttle Lever	1
8	KL0707008	Socket Head Bolt 6x16	1	30	KL0707030	Lever Pin	1
8A	KL0707008A	Washer	1	31	KL0707031	Valve Body	1set
9	KL0707009	Drive Pulley	1	32	KL0707032	'O' Ring	1
10	KL0707010	Flat Shoe	1	33	KL0707033	'O' Ring	1
11	KL0707011	Socket Head Bolt 5x118	1	34	KL0707034	'O' Ring S-7	1
12	KL0707012	Dust Cover	1	35	KL0707035	Valve Stem	1
13	KL0707013	Guard Body	1	36	KL0707036	'O' Ring	1
14	KL0707014	Tension Bar	1set	37	KL0707037	Valve Spring	1
15	KL0707015	Spring	1	38	KL0707038	Deflector	1
16	KL0707016	Lever Pin	1	39	KL0707039	Air Inlet	1
17	KL0707017	Lever Pin	1	40	KL0707040	Hek Wrench Key 4	1
18	KL0707018	Housing	1	7		Grinding Belt AA 80x10	1
19	KL0707019	Ball Bearing EE3	1	7		Grinding Belt AA 100x10	1

Hand-Arm Vibration

All hand held power tools vibrate to some extent, and this vibration is transmitted to the operator via the handle, or hand used to steady the tool. Vibration from about 2 to 1500 herz is potentially damaging and is most hazardous in the range from about 5 to 20 herz.

Operators who are regularly exposed to vibration may suffer from Hand Arm Vibration Syndrome (HAVS), which includes 'dead hand', 'dead finger', and 'white finger'. These are painful conditions and are widespread in industries where vibrating tools are used.

The health risk depends upon the vibration level and the length of time of exposure to it.....in effect, a daily vibration dose.

Tools are tested using specialised equipment, to approximate the vibration level generated under normal, acceptable operating conditions for the tool in question. For example, a grinder used at 45° on mild steel plate, or a sander on softwood in a horizontal plane etc.

These tests produce a figure expressed in metres per second, which represents the vibration level, and which appears in the specification panel of the Operating and Maintenance instruction manual.

It should be noted that if a tool is used under abnormal, or unusual conditions, then the vibration level could possibly increase significantly. Users must always take this into account and make their own risk assessment.

Values in excess of 2.5 m/s are considered hazardous when used for prolonged periods. A tool with a vibration value of 2.8 m/s may be used for up to 8 hours (cumulative) per day, whereas a tool with a value of 11.2 m/s may be used for ½ hour per day only.

The graph below shows the vibration value against the maximum usable time it may be used, per day.

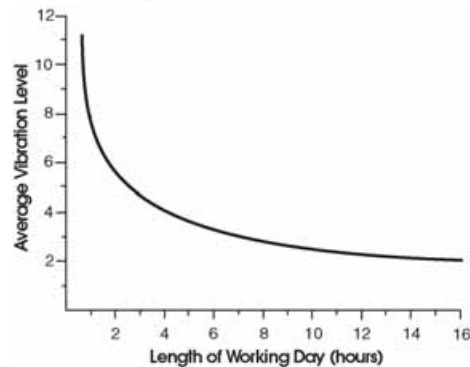

Some tools with a high vibration value, such as impact wrenches, are generally used for a few seconds at a time, therefore the cumulative time may only be in the order of a few minutes per day. Nevertheless, the cumulative effect, particularly when added to that of other hand held power tools that may be used, must always be taken into account.

Employers are advised to refer to the HSE publication "Guide for Employers".

Recommended Air supply Connections

